

AIR FRYER

Instruction Manual & Guarantee

Dualit®

Since 1945

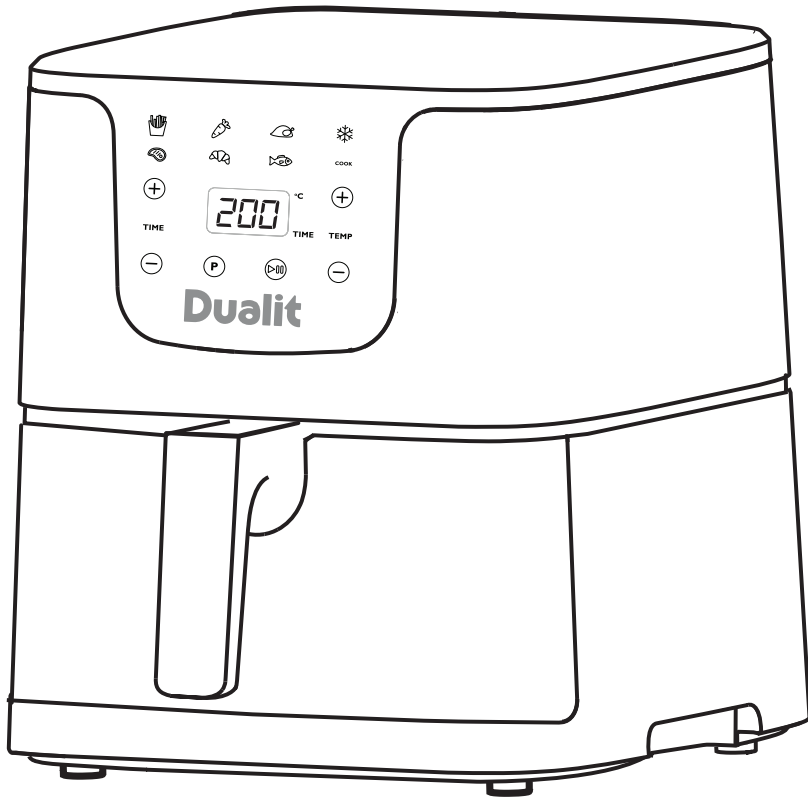

**REGISTER YOUR PRODUCT FOR THE CHANCE TO
WIN A £250 PRIZE DRAW!**

**DON'T FORGET
TO REGISTER
YOUR PRODUCT**

WWW.DUALIT.COM/REGISTER

OR BY POST



Dualit[®]

AIR FRYER

CONGRATULATIONS ON PURCHASING YOUR AIR FRYER

Enjoy delicious food while saving time, energy and money using your powerful Air Fryer.

Designed to the highest specifications, the Air Fryer uses convection heating (circulating hot air around the food), as opposed to frying, to provide a healthy alternative to deep fat fryers. All without compensating on flavour.

With a large capacity (5.5L) but small footprint, this mighty appliance will supercharge your cooking, enabling you to fry, bake, roast, dehydrate, grill and reheat at the touch of a button. Our thoughtfully designed non-stick coated Crisper Tray maximises the amount of food you can cook, while also allowing for easy cleaning in the dishwasher.

With the flexibility to choose one of the Air Fryer's useful Presets or Manual Mode cooking, there are countless meal options to choose from.

AIR FRYER RECIPE INSPIRATION

To access a comprehensive database of recipes, with ideas for everyday meals and entertaining visit: www.dualit.com/recipes or simply scan the QR code below.



★ RECIPES ★



CONTENTS

Safety precautions	04
Know your Air Fryer	07
Crisper Plate Orientation	08
Controls & functions	09
Setting up your Air Fryer	11
Before first usage	13
Preheating your Air Fryer	14
Know your Air Fryer Presets	15
Using your Air Fryer Presets	16
Know your Air Fryer Manual Mode	19
Using your Air Fryer Manual Mode	23
Tips for using your Air Fryer	24
Cleaning & maintenance	25
Troubleshooting	27

REGISTER YOUR PRODUCT FOR THE CHANCE TO WIN A £250 PRIZE DRAW!

DON'T FORGET TO REGISTER YOUR PRODUCT	WWW.DUALIT.COM/REGISTER	
	OR BY POST	

Unpack the box with care, keeping all the packaging materials until you are satisfied everything is present and in working order. Once satisfied remove any tags from the appliance body and recycle the packaging appropriately. Do not remove tags from the cord. You may wish to keep the box to store your appliance.

All illustrations are for representation only; your model may vary from illustrations shown.



IMPORTANT SAFETY PRECAUTIONS



READ ALL INSTRUCTIONS KEEP THESE INSTRUCTIONS FOR FUTURE REFERENCE IMPORTANT SAFEGUARDS

• THIS IS AN ATTENDED APPLIANCE.

- Do not leave appliance unattended during use, unplug after each use, as there is a risk of fire if an unattended appliance is left operating or plugged in. **Risk of fire.**
- This appliance must not be used by children younger than 8 years old and persons with very extensive and complex disabilities. Children aged 8-14 years and persons with reduced physical, sensory or mental capabilities or lack of experience and knowledge shall not use this appliance, unless they are supervised and have been given instruction concerning the use of the appliance in a safe way and understand the hazards involved. Children shall not play with the appliance. Cleaning and user maintenance shall not be made by children unless they are older than 8 and supervised. Keep the appliance and its cord out of reach of children less than 8 years old.
- This appliance is intended for household use only. If the appliance is used improperly or for professional or semi-professional purposes or if it is not used according to these instructions the Guarantee becomes invalid and Dualit refuses any liability for damage caused.

Electrical Safety

Before connecting to the mains supply:

- Check that the voltage marked on the appliance corresponds with the supply voltage. **Risk of electric shock and fire.**
- We recommend that the appliance is plugged into a socket that has no other appliance connected to it. Failure to do this may cause an overload, trip a circuit breaker or blow a fuse. Preferably the socket outlet should be protected by a Residual Current Device (RCD).
- If you have finished using the appliance, unplug it from the mains. **Risk of fire.** Allow the appliance to cool for one hour before moving, cleaning or storing. **Risk of injury.**

- The appliance is not intended to be operated by means of an external timer or separate remote-control system. **Risk of fire.**
- To be protected against electrical hazards, fire and injury to persons, do not immerse the mains lead, plug or appliance in water or any other liquid. **Risk of electric shock.**
- NOTE: Any plug cut from the power supply cord should be disposed of immediately. Inserting any cut off plug into a 13A socket-outlet is hazardous. **Risk of electric shock and fire.**
- Do not operate any appliance with a damaged lead or plug, or after the appliance malfunctions or has been dropped, damaged or cracked in any manner. **Risk of fire, electric shock and injury.**
- In order to avoid a hazard, if the Power Cord is damaged it must, for safety reasons, be replaced by Dualit or an authorised Dualit repairer. Call Dualit's Customer Helpline on +44 (0)1293 652 500.
- Never use the plug without the fuse cover fitted. Ensure replacement fuse is the same current value as the original. Replacement fuses are available and should be ASTA approved to BS1362.
- **Warning!** This appliance must be earthed.
- Do not clean with metal scouring pads. Pieces can break off the pad and touch electrical parts. **Risk of electric shock.**
- To disconnect the appliance, press and hold the Power/ Play/ Pause button for 3 seconds, then remove the plug from the wall outlet. **Risk of fire.**

General Safety

- Do not place on or near a hot gas or electric burner, or in a heated oven. **Risk of fire.**
- Do not use in bathroom or outdoors. **Risk of electric shock.**
- To ensure even cooking results, we recommend cutting food items into similar shapes and sizes and preheating your appliance before using. When cooking meat, fish and frozen finger food preheating is essential. **Risk of harm.**
- Extreme caution must be used when moving an appliance containing hot oil or other hot liquids. **Risk of scalding.**

- Unplug the appliance from the wall socket when not in use and before moving and cleaning. **Risk of fire.**
- Do not move the appliance while it is switched on. **Risk of scalding.**
- When moving the appliance, use both hands and lift holding the Base. Do not attempt to lift by the Crisper Tray handle. Do not touch hot surfaces. **Risk of scalding.**
- Use extreme caution when removing the Crisper Plate or Crisper Tray when disposing of hot grease. **Risk of scalding.**
- **Warning - steam hazard:** During use, hot air and steam will be emitted from the appliance. Scalding may occur if you are within 40cm of the Hot Air Exhaust. Keep your hands and face at a safe distance from the steam and from the Hot Air Exhaust. Also, be careful of hot steam and air when you remove the Crisper Tray from the appliance. **Risk of scalding.**
- **Caution:** vents are hot. **Risk of scalding.**
- Immediately unplug the appliance if dark smoke is emitted from the appliance. Wait for the smoke emission to stop before you remove the Crisper Tray from the appliance. **Risk of fire.**
- Empty and clean the Crisper Plate and the Crisper Tray on a regular basis. A build up of crumbs, food or oil can burn or cause fire. Pull out the Crisper Plate and Crisper Tray and follow the Cleaning & Maintenance instructions on page 25. **Risk of fire and injury.**
- Do not cover any internal part of the appliance with metal foil, this will cause overheating of the appliance. **Risk of electric shock.**
- Do not allow cable to touch hot surfaces, or to hang over edge of a table or counter top. **Risk of fire or electric shock.**
- Do not use appliance for any purpose other than the intended use. **Risk of fire, electric shock, scalding and injury.**
- Do not store or use in an appliance garage or under cupboards. **Risk of fire.**
- The use of accessory attachments is not recommended by Dualit. **Risk of fire, electric shock and injury.**
- Do not attempt to dislodge food when the appliance is plugged into an electrical outlet. **Risk of electric shock.**

- Do not place the appliance on a tray or surface that can collect water. **Risk of fire and electric shock.**
- Oversized foods, metal foil packages and utensils must not be inserted in the appliance. **Risk of fire and electric shock.**
- Do not insert anything into the ventilation slots and do not obstruct them. **Risk of fire.**
- Do not place any of the following materials in the appliance: paper, cardboard, plastic and similar products. **Risk of fire.**
- The appliance must only be used in an upright position, never lying down, tilted or upside down. **Risk of fire.**
- In the event of a fire, unplug the appliance from the mains and cover with a fire blanket. **Risk of injury.**
- Never pick up product using the Crisper Tray Handle. **Risk of injury.**
- Use caution when turning the Crisper Tray over after cooking, as the hot Crisper Plate may fall out and create a safety hazard. **Risk of injury and product damage.**
- We recommend preheating your appliance for 3 minutes before using. Preheating is essential when cooking meat, fish and frozen food. **Risk of harm.**
- Never place anything on top of your Air Fryer, this will disrupt air flow to the Air Inlet. Do not cover, block, or try to remove Cover. **Risk of fire and injury.**
- Use oven gloves to remove any object inside the appliance. **Risk of injury.**
- Use recommended cooking temperature settings.
- Do not use non-Dualit accessories in Air Fryer. **Risk of fire and product damage.**
- Do not place the appliance against a wall or against other appliances. Do not place anything within 20cm of the rear of the Air Fryer, including electrical wall sockets. Never place below or against a flammable surface. A fire may occur if the appliance is covered or touching flammable materials such as curtains, drapes and walls, when in operation. **Risk of fire.**



IMPORTANT SAFETY PRECAUTIONS



- Never block or obstruct the Hot Air Exhaust. **Risk of injury and fire.**
- Never attempt to open the appliance if the appliance should catch fire. **Risk of injury.**
- Never tamper with the safety systems. They are included for your personal safety. **Risk of injury.**
- Do not operate on an uneven surface. The appliance must only be operated on a flat, horizontal surface. **Risk of injury.**
- Always check food is thoroughly cooked and piping hot before serving (i.e. above 75°C for at least 30 seconds). **Risk of harm.**
- Always place the appliance's Crisper Tray on a heat resistant surface. If a supporting hand is needed to carry Crisper Tray in addition to the handle, use oven gloves. **Caution:** Crisper Tray base and sides will be hot. **Risk of injury.**
- Always ensure there is a minimum of 2cm distance between the top of food and top of Crisper Tray. Do not over fill the appliance with food. Overfilling may cause contact between food and the heating element. **Risk of fire and injury.**
- **Warning:** The Air Fryer is not a deep fat fryer and must never be used with more than 30ml of any type of cooking oil or 30g solid lard/ fat. Your Air Fryer will work with no oil or fat. **Risk of fire.**
- **Warning:** Do not try to open the top of the Air Fryer. This is not a lid. **Risk of injury and electric shock.**
- **Warning:** do not allow liquid to get into the Air Inlet. **Risk of fire and electric shock.**



Accessible surfaces of the appliance may get hot during use. Therefore use handles. **Risk of injury.**

SAVE THESE INSTRUCTIONS

In the interest of improving products, Dualit Ltd. reserves the right to change the product specification without prior notice.

INSTRUCTIONS ON ENVIRONMENT PROTECTION



Do not dispose of this product in the usual household garbage at the end of its life cycle. Please hand it over to a collection point for the recycling of electrical and electronic appliances.

The symbol on the product, the instruction of use or the packaging will inform you about the methods of disposal. The materials are recyclable as mentioned on its marking. By recycling, material recycling or other forms of re-utilization of old appliances you are making an important contribution to protect our environment. Please enquire about the community administration for the authorised disposal location.

KNOW YOUR AIR FRYER

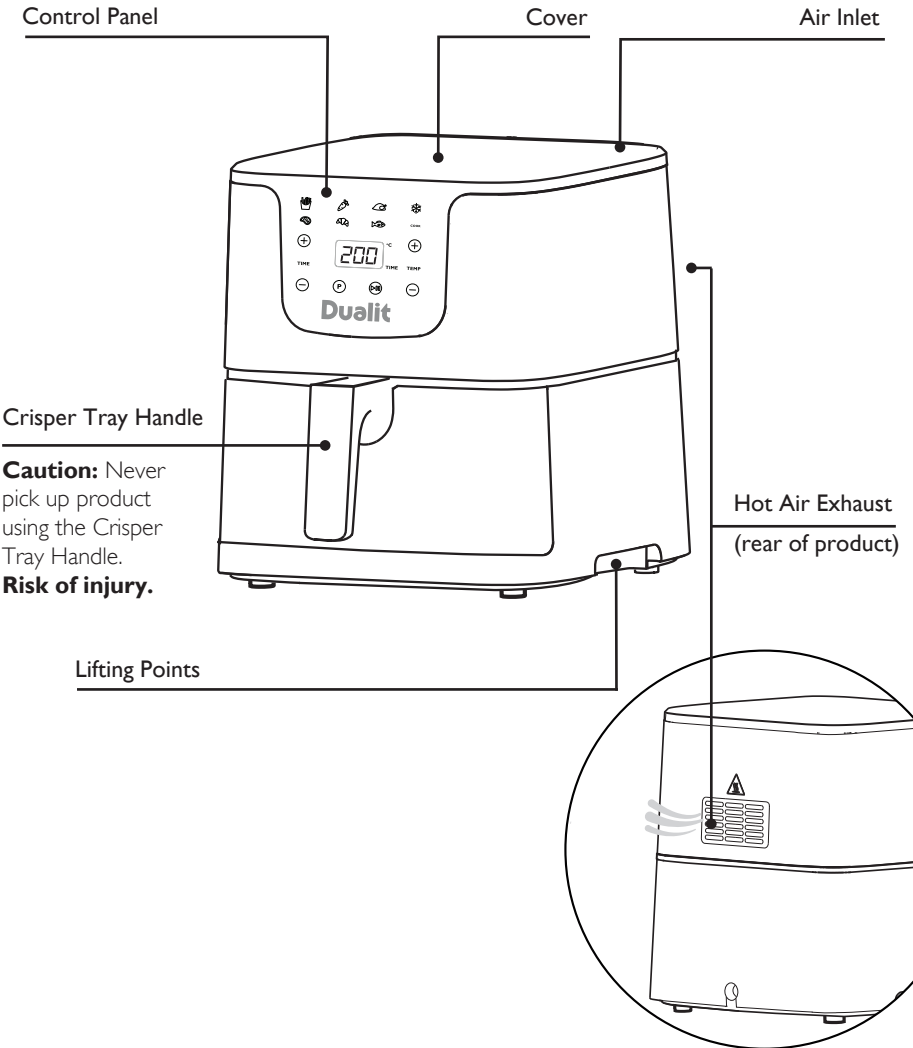

CRISPER PLATE ORIENTATION

Caution: Crisper Plate must be orientated correctly into the Crisper Tray. Damage may occur to non-stick coating or the Crisper Plate may become stuck if positioned incorrectly.

Crisper Plate Orientation Arrows: Arrows should always be positioned on the opposite side to the Handle, when assembled in Crisper Tray.

Crisper Plate Ring Pull Orientation: Crisper Plate Ring Pull should always be positioned on the Top, when assembled in Crisper Tray.

The four Rubber Spacers keep the Crisper Plate fitted to the bottom of the Crisper Tray. Only remove the Rubber Spacers for cleaning purposes. To clean them, see 'Cleaning & maintenance' instructions on page 25.

See 'Setting Up Your Air Fryer' on page 11 for detailed assembly instructions.

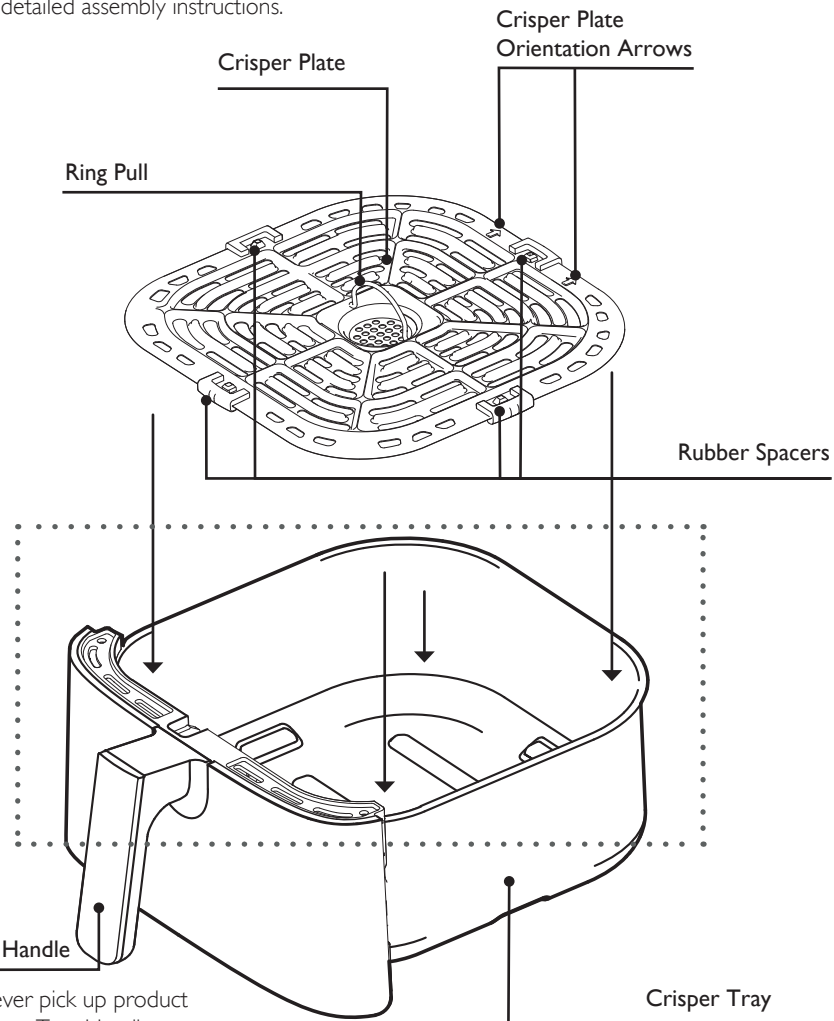

Crisper Tray Handle

Caution: Never pick up product using the Crisper Tray Handle.

Risk of injury.



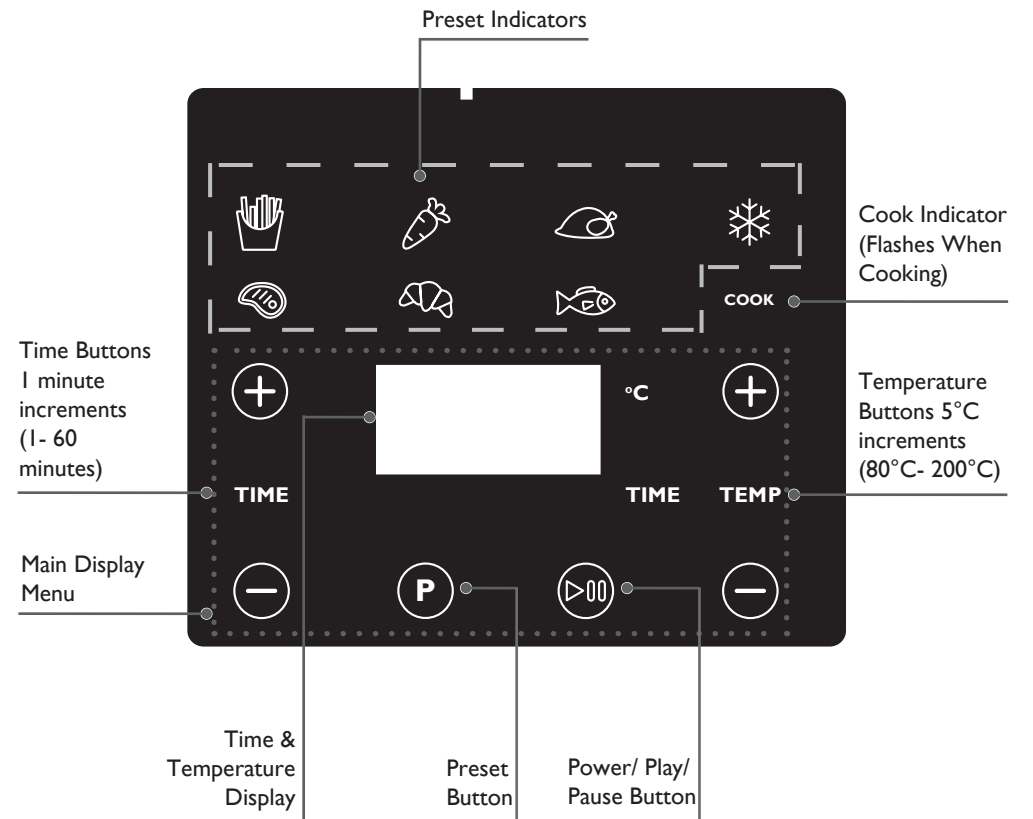





CONTROLS & FUNCTIONS



ENERGY-SAVING:

After 5 minutes of no activity from user, the Air Fryer will enter Standby Mode automatically. To exit this mode, press the Power/ Play/ Pause button.

CONTROLS & FUNCTIONS

Icon & Button Name	Function
 TIME	Increases the time by 1 minute increments. The time can be increased at any point during the cooking cycle. This can also be used to adjust Preset timings.
 TIME	Decreases the time by 1 minute increments. The time can be decreased at any point during the cooking cycle. This can also be used to adjust Preset timings.
 TEMP	Increases the temperature by 5°C increments. The temperature can be increased at any point during the cooking cycle. This can also be used to adjust Preset temperatures.
 TEMP	Decreases the temperature by 5°C increments. The temperature can be decreased at any point during the cooking cycle. This can also be used to adjust Preset temperatures.
 PRESET	Press repeatedly to scroll through the 7 Presets (see page 15 for further details on Presets). Always check that food is cooked thoroughly before serving. To exit Preset mode continue to press the P button until no further icons are illuminated.
 POWER/ PLAY/ PAUSE	If in Standby Mode, press once to bring up the Main Display menu. If the Main Display menu is showing, press once to start the cooking cycle. If the cooking cycle is running, press once to pause cooking. End of cycle: Flashes 'Off' on display, beeps 5 times and enters Standby Mode. Manual turn off: Press and hold this button, appliance will beep once to indicate button press. Flashes 'Off' on display, beeps 5 times and enters Standby Mode.
 TIME & TEMPERATURE DISPLAY	Alternately displays the set Cooking Time and Temperature. Once the cooking cycle begins, it will display the Cooking Time remaining and the Temperature for 5 seconds each.
 COOK COOK INDICATOR	Flashes when cooking and to indicate cooling when entering Standby mode.

SETTING UP YOUR AIR FRYER



ENSURE YOU HAVE READ THE 'IMPORTANT SAFETY PRECAUTIONS' ON PAGE 04. FOLLOW THE SETUP INSTRUCTIONS OUTLINED BELOW TO MINIMISE SAFETY RISKS AND ENSURE APPROPRIATE USAGE OF THE AIR FRYER. **RISK OF FIRE AND INJURY.**

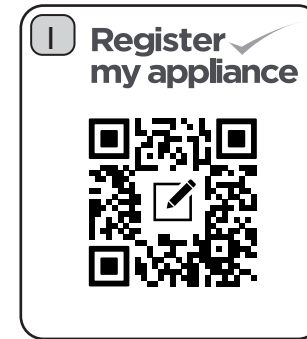

Register your product at www.dualit.com/register. This takes 60 seconds. You will need the product model and serial number, which are located on the label on the base of the product.

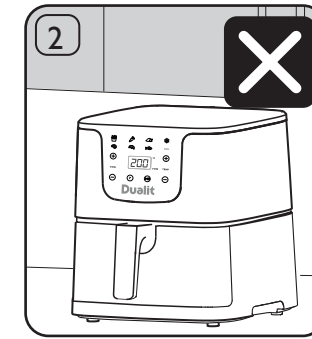

This is an attended appliance. Never leave appliance unattended during use. Unplug after each use. **Risk of fire.**

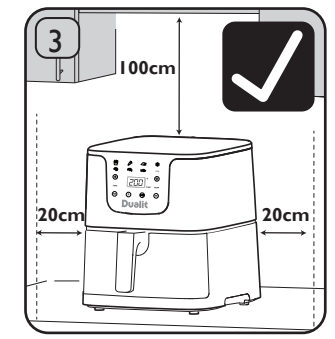

Position the Air Fryer on an open, level surface, at least 100cm from overhanging cupboards and 20cm from walls or cupboards on all sides. **Risk of fire.** Do not store or use your Air Fryer in an appliance garage or under cupboards. Do not place your Air Fryer on a tray or surface that can collect water.

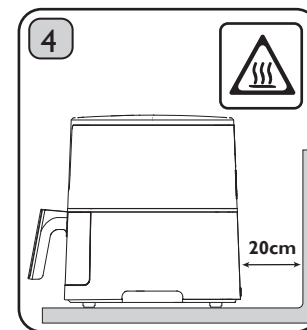

Caution: Do not place anything within 20cm of the rear of the Air Fryer, including electrical wall sockets. Never place below or against a flammable surface. Never block or obstruct the Hot Air Exhaust. **Risk of injury and fire.**

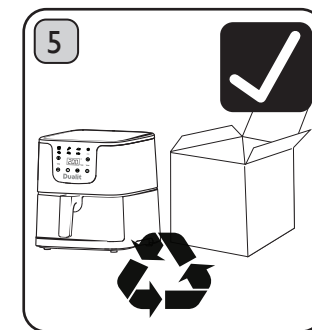

Remove the Crisper Tray from the Air Fryer and lift out the Crisper Plate. Remove all packaging (exterior boxes, films, dust bag, and cardboard inserts inside Crisper Tray) and then reassemble. **Caution:** Failure to remove all packaging will cause a **fire risk**. Ensure all parts are checked before use.

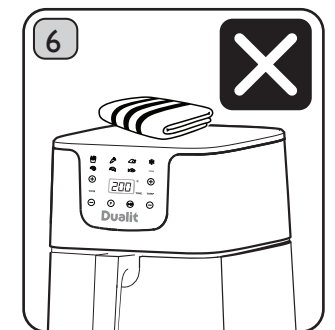

Never place anything on top of your Air Fryer, this will disrupt air flow to the Air Inlet and cause poor cooking results. **Risk of fire and injury.** Always ensure you have access to a fire blanket when using the appliance. **Risk of fire.**

SETTING UP YOUR AIR FRYER CONT'D

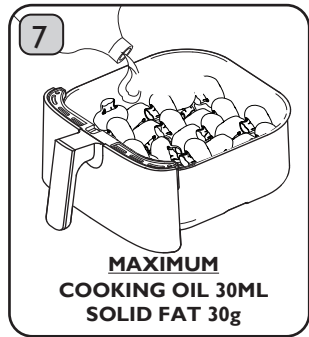

Caution: The Air Fryer is not a deep fat fryer and must never be used with more than 30ml of any type of cooking oil or 30g solid lard/fat. **Risk of fire.** Your Air Fryer will work with no oil or fat.

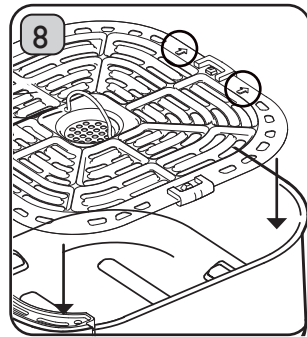

To insert the Crisper Plate, pick it up using the Ring Pull and identify the Crisper Plate Orientation Arrows that are on the Crisper Plate. Orientate the Crisper Tray so that the Crisper Plate Orientation Arrows point away from the Crisper Tray Handle. Lower side opposite the Crisper Plate Orientation Arrows into the Crisper Tray.

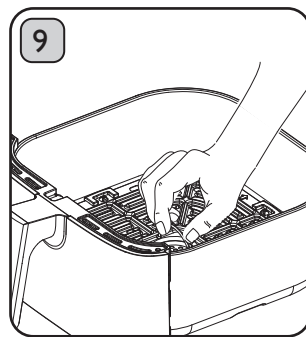

Then lower side with arrows into the Crisper Tray. Never position with Ring Pull facing down or arrows pointing towards handle. **Risk of damage** to non-stick coating/ Crisper Plate getting stuck in Crisper Tray.

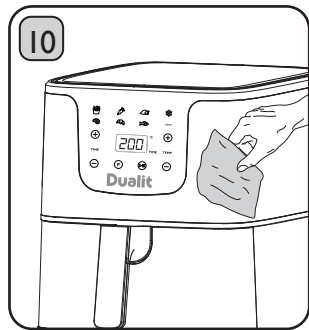

Before use, follow the Cleaning & maintenance instructions on page 25.

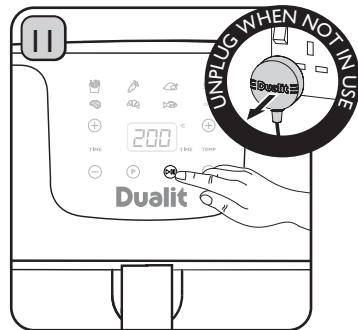

If you are not using this appliance for the first time, skip steps on 'Before First Usage' on page 13 and move on to 'Preheating Your Air Fryer' on page 14.

BEFORE FIRST USE



ENSURE YOU HAVE READ 'IMPORTANT SAFETY PRECAUTIONS' ON PAGE 04 AND 'SETTING UP YOUR AIR FRYER' ON PAGE 11. TURN YOUR AIR FRYER ON FOR THE FIRST TIME IN A WELL VENTILATED ROOM. A 'NEW' SMELL MAY BE GIVEN OFF, THIS WILL DISSIPATE AFTER A FEW USES.

THE FOLLOWING STEPS ARE ONLY NECESSARY BEFORE FIRST USAGE

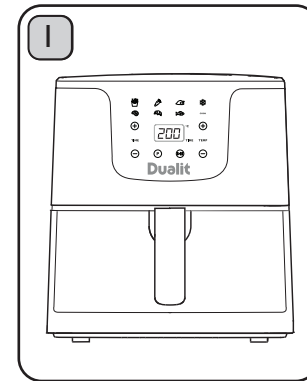

Plug your Air Fryer into the mains. The appliance will beep once and the Power/ Play/ Pause Button will illuminate red, indicating Standby Mode.

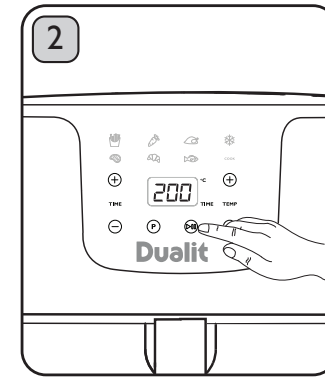

Press the Power/ Play/ Pause Button to illuminate the Main Display Menu.

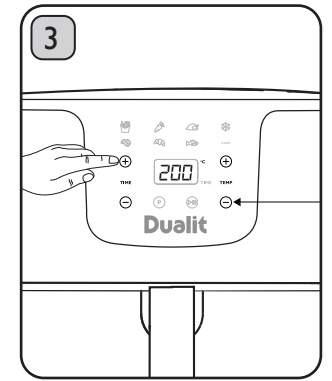

Use the +/- Time Buttons to set the time for 5 minutes. Use the +/- Temp Buttons to set the temperature to 200°C.

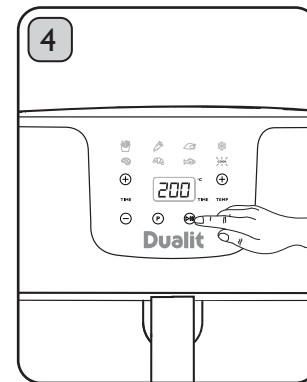

Once you have set the time and temperature, press the Power/ Play/ Pause Button to start the cooking cycle. The Cooking Indicator will illuminate and flash.

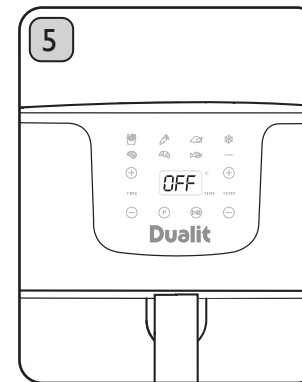

When the cooking cycle is finished the appliance flashes 'Off' on the display, beeps 5 times and enters Standby Mode.

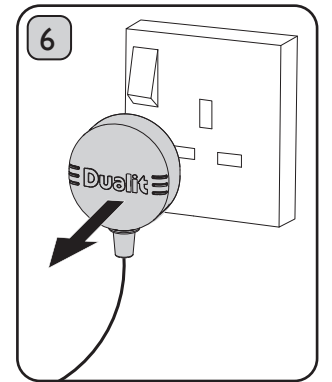

If you have finished using the appliance, unplug it from the mains. **Risk of fire.** Allow the appliance to cool for one hour before moving, cleaning or storing. **Risk of injury.**

PREHEATING YOUR AIR FRYER

ENSURE YOU HAVE READ 'IMPORTANT SAFETY PRECAUTIONS' ON PAGE 04 AND FOLLOWED THE STEPS ON 'SETTING UP YOUR AIR FRYER' ON PAGE 11.



We recommend preheating your appliance for 3 minutes before using. Preheating is essential when cooking meat, fish and frozen food. **Risk of harm.**

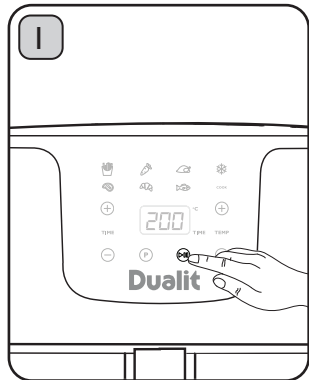

Plug your Air Fryer into the mains. The appliance will beep once and the Power/Play/Pause Button will illuminate red, indicating Standby Mode. Press the Power/ Play/ Pause Button to view the Main Display Menu.

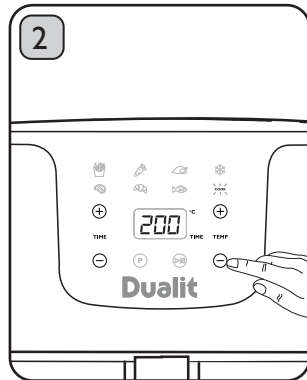

Press the Temp +/- Buttons and the Time +/- Buttons to manually set the Time and Temperature to your desired settings. Set the appliance to your desired cooking temperature and set the timer to 3 minutes.

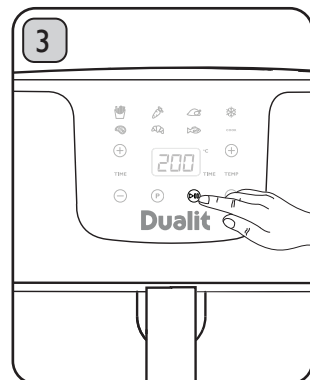

Press the Power/ Play/ Pause Button to start the cooking cycle. The Cooking Indicator will illuminate and flash.

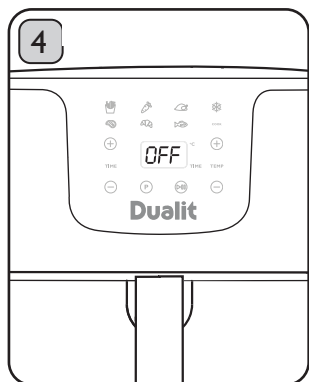

When the cooking cycle is finished the appliance flashes 'Off' on display, beeps 5 times and enters Standby Mode.

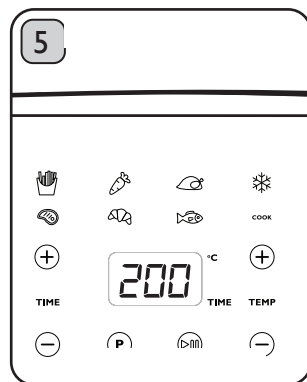

Proceed to 'Know Your Air Fryer Presets' on page 15 and/ or 'Know Your Air Fryer Manual Mode' on page 19.

KNOW YOUR AIR FRYER PRESETS

ENSURE YOU HAVE READ 'IMPORTANT SAFETY PRECAUTIONS' ON PAGE 04 AND FOLLOWED THE STEPS ON 'SETTING UP YOUR AIR FRYER' ON PAGE 11 AND 'PREHEATING YOUR AIR FRYER' ON PAGE 14.



PRESETS AND RECOMMENDED COOKING GUIDELINES

Presets are recommended time and temperature settings to cook the foods listed below. These are suggested guidelines, actual cooking times may vary. If using less food than stated below, consider reducing cooking times. Always preheat the appliance for 3 minutes, cut food into evenly sized pieces and turn/ shake halfway through cooking. We recommend not using a wet batter when cooking in your Air Fryer. Never exceed maximum weight per cycle. **Risk of fire.**

Icon	Preset function	Time (minutes)	Temperature (°C)	Maximum weight per cycle (kg)
	French fries	20	200	Thin cut: 0.7kg Thick cut: 0.5kg
	Vegetables	15	190	0.3kg
	Meat on the bone e.g. pork chops, chicken drumsticks, chicken thighs (excluding larger joints of meat)	20	180	0.5kg
	Frozen Finger Food e.g. chicken nuggets, hash browns. Note: this is not to be used as a defrost function	20	180	0.5kg
	Meat fillet e.g. chicken breast/ steak	15	200	2x0.25kg Fillet
	Bakery e.g. pre-prepared croissants	12	200	0.5kg
	Fish e.g. salmon steak, tuna steak (excluding whole fish on the bone)	7	200	2x0.15kg Fillet

USING YOUR AIR FRYER PRESETS

ENSURE YOU HAVE READ 'IMPORTANT SAFETY PRECAUTIONS' ON PAGE 04 AND FOLLOWED THE STEPS ON 'SETTING UP YOUR AIR FRYER' ON PAGE 11 AND 'PREHEATING YOUR AIR FRYER' ON PAGE 14.

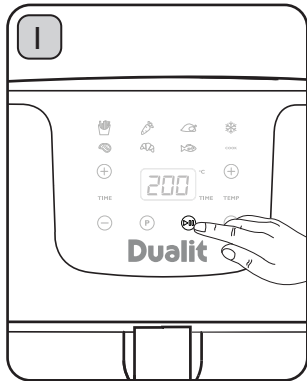

Plug your Air Fryer into the mains. The appliance will beep once and the Power/Play/Pause button will illuminate red, indicating Standby Mode.

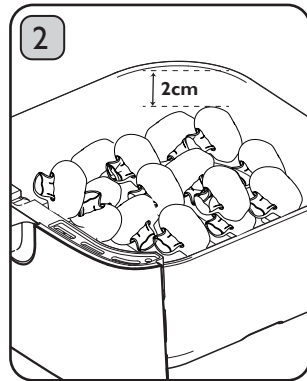

Evenly distribute food on the Crisper Plate. Ensure a 2cm gap between food and top of Crisper Tray. Do not squash food. See 'Presets and Recommended Cooking Guidelines' on page 15. Never exceed 'Maximum weight per cycle (kg)' on page 15.
Risk of fire.

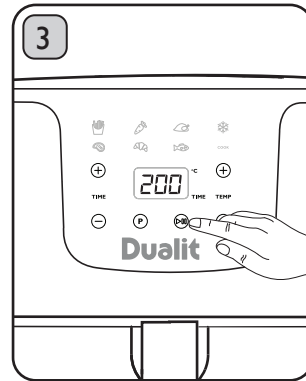

Insert the Crisper Tray back into the appliance. Press Power/Play/Pause button to view the Main Display Menu.

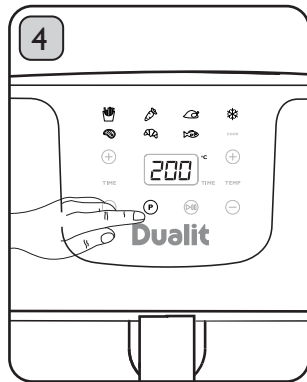

Select a Preset by pressing the P button until the desired icon is illuminated on the Main Display Menu. To exit Preset mode continue to press the P button until no Preset icons are illuminated.

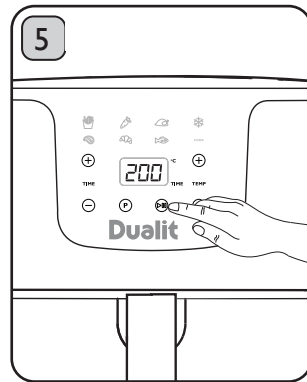

Press the Power/Play/Pause button again to start the cooking cycle. During the cooking cycle, the Cooking Indicator will illuminate and flash.

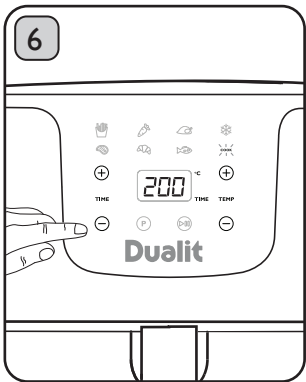

To change the time and temperature of the Preset, press Temp +/- and Time +/- buttons. To pause/restart press the Power/Play/Pause button. The Power/Play/Pause button will flash when in Pause Mode.

USING YOUR AIR FRYER PRESETS CONT'D

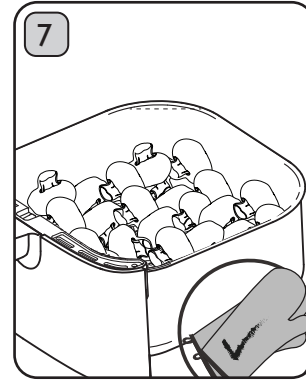

For even cooking results, we recommend turning/shaking food several times during the cooking cycle; pull out the Crisper Tray, shake/turn food then reinsert Crisper Tray. Cooking will automatically resume.
Risk of injury.

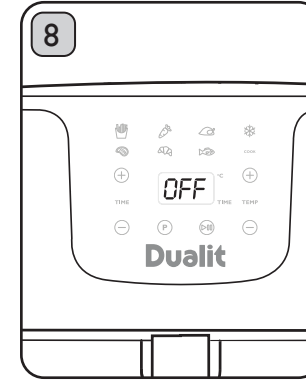

When the cooking cycle is finished the appliance flashes 'Off' on display, beeps 5 times and enters Standby Mode.

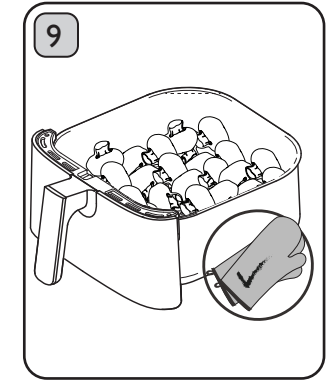

When removing, place Crisper Tray on heatproof surface. **Risk of injury.** If a supporting hand is needed to carry Crisper Tray in addition to the handle, use oven gloves. **Caution:** Crisper Tray base and sides will be hot. **Risk of injury.**

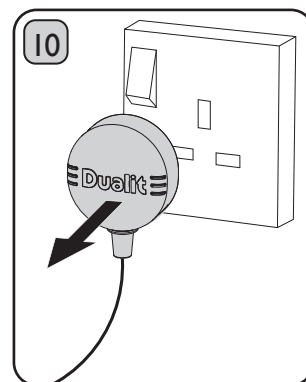

If you have finished using the appliance, unplug it from the mains and allow it to cool for one hour before cleaning. **Risk of injury.** Always unplug when not in use. **Risk of fire.**

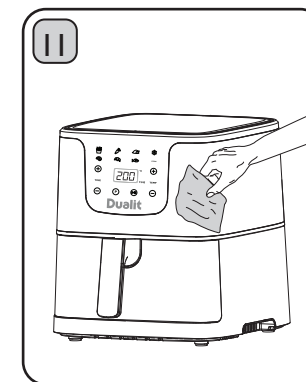

Always follow the Cleaning & maintenance instructions on page 25 after every use. **Risk of fire and injury.**

DISCOVER Dualit® AIR FRYER RECIPES HERE

KNOW YOUR AIR FRYER MANUAL MODE



ENSURE YOU HAVE READ 'IMPORTANT SAFETY PRECAUTIONS' ON PAGE 04 AND FOLLOWED THE STEPS ON 'SETTING UP YOUR AIR FRYER' ON PAGE 11 AND 'PREHEATING YOUR AIR FRYER' ON PAGE 14.

MANUAL MODE AND RECOMMENDED COOKING GUIDELINES

These are recommended time and temperature settings to cook the foods listed below. These are suggested guidelines, actual cooking times may vary. If using less food than stated below, consider reducing cooking times. Always preheat the appliance for 3 minutes, cut food into evenly sized pieces and turn/ shake halfway through cooking. We recommend not using a wet batter when cooking in your Air Fryer. Never exceed maximum weight per cycle. **Risk of fire.**

MANUAL COOKING GUIDE

Cook	Food	Time (minutes)	Temperature (°C)	Maximum weight per cycle (kg)	Food Preparation
Roast Meat	Pork Joint	60	180	1kg	None
	Roast Chicken	50	170	1.2kg	None
	Beef Joint	50	160	1kg	None
Roast Vegetables	Cabbage Steaks	10	200	0.4kg	Parboil 3-5 mins
	Peppers	15	190	0.4kg	Cut each into 4 slices
	Parsnips	25	190	1kg	Cut into eighths lengthways (not rounds)
	Carrots	25	190	1kg	Cut into eighths lengthways (not rounds)
	Potatoes	30	190	1kg	Cut into 2.5cm slices
	Mushrooms	10	200	0.5kg	None



SCAN HERE
FOR HEALTHY
RECIPES!

KNOW YOUR AIR FRYER MANUAL MODE CONT'D



Cook	Food	Time (minutes)	Temperature (°C)	Maximum weight per cycle (kg)	Food Preparation
Fry	Frozen French Fries Thick Cut	20	200	0.5kg	None
	Frozen French Fries Thin Cut	20	200	0.7kg	None
	Chicken Wings	20	180	1kg	None
	Brussel Sprouts	20	190	0.4kg	Halved
	Chicken Breasts	20	200	1kg	None
	Pre-made Onion Rings (Chilled)	10	200	0.4kg	None
	Pre-made Onion Rings (Frozen)	15	180	0.4kg	None

KNOW YOUR AIR FRYER MANUAL MODE CONT'D

Cook	Food	Time (minutes)	Temperature (°C)	Maximum weight per cycle (kg)	Food Preparation
Grill	Salmon Steaks	9	200	0.48kg	None
	Lamb Chops	12	190	0.5kg	None
	Steaks	8-12	200	0.8kg	None
	Burgers	15	190	0.68kg	None
	Garlic bread (Chilled)	7	160	1 baguette	Halved
	Garlic bread (Frozen)	10	150	1 baguette	Halved
	Sausages	10	170	0.4kg (6 pack)	Prick with sharp knife
Reheat	Bean Tacos	5	108	4 tacos	None
	Potatoes	10	180	1kg	None
	Lamb Chops	4	170	0.5kg	None
	Pizza (Chilled)	12	160	Small pizza	None
Dehydrate	Strawberries	4x60	80	Cut in 0.5cm/ 1 cm slices and arrange in a single layer	
	Apples	5x60	80	Core, cut in 3mm slices, rinse in lemon water and pat dry, arrange in a single layer	
	Bananas	5x60	80	Peel and cut in 3mm slices and arrange in a single layer	

USING YOUR AIR FRYER MANUAL MODE



ENSURE YOU HAVE READ 'IMPORTANT SAFETY PRECAUTIONS' ON PAGE 04 AND FOLLOWED THE STEPS ON 'SETTING UP YOUR AIR FRYER' ON PAGE 11 AND 'PREHEATING YOUR AIR FRYER' ON PAGE 14.

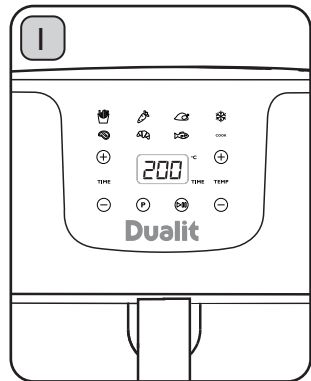

Refer to the steps on 'Know Your Manual Mode' on page 19. Ensure you have followed the steps on 'Crisper Plate Orientation' on page 08.

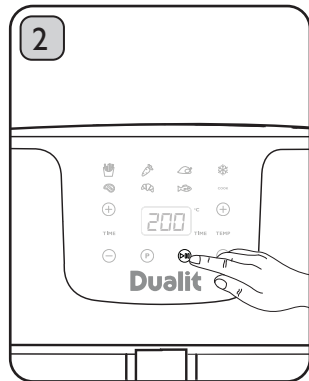

Plug the Air Fryer into the mains. The appliance will beep once and the Power/ Play/ Pause button will illuminate red, indicating that the appliance is in Standby Mode.

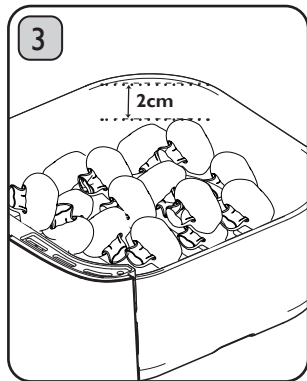

Distribute food evenly and ensure a 2cm gap between food and top of Crisper Tray. Do not squash food. See recommended cooking times on page 19. **Risk of fire.** In the event of fire, unplug appliance from mains and cover with fire blanket.

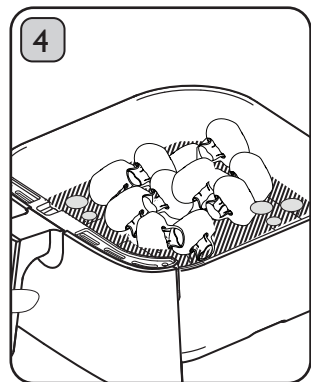

If the recipe includes a sauce, use the Air Fryer without the Crisper Plate, by placing the food and sauce directly into the Crisper Tray. Caution when pouring sauce out of the Crisper Tray. **Risk of injury.**

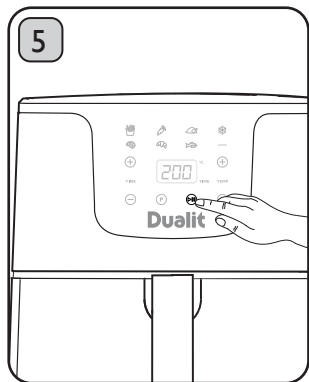

Insert the Crisper Tray into the appliance. Press the Power/ Play/ Pause button to view the Main Display Menu.

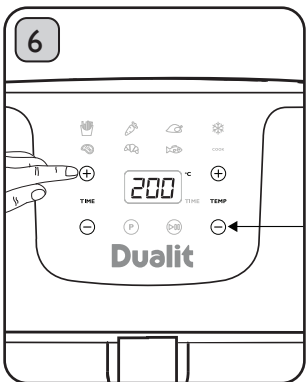

Press the Temp +/- buttons and Time +/- buttons to manually set the time and temperature. Press the Power/ Play/ Pause button again to start the cooking cycle. During the cooking cycle, the Cooking Indicator will illuminate and flash.

USING YOUR AIR FRYER MANUAL MODE CONT'D

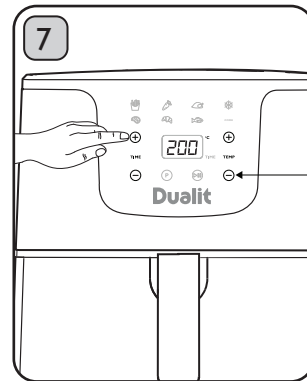

To change Time and Temp during cooking, press Temp +/- buttons and Time +/- buttons. To pause/ restart press the Power/ Play/ Pause button. The Power/ Play/ Pause button will flash when in Pause Mode.

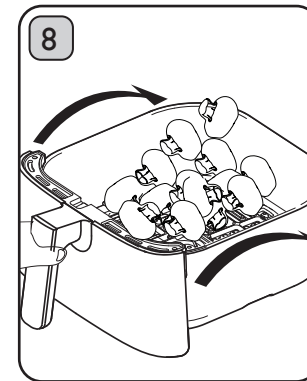

To achieve even cooking results, we recommend turning/ shaking food several times during the cooking cycle. To do so, pull out the Crisper Tray, shake/ turn food and reinsert the Crisper Tray. Cooking will automatically resume. **Risk of injury.**

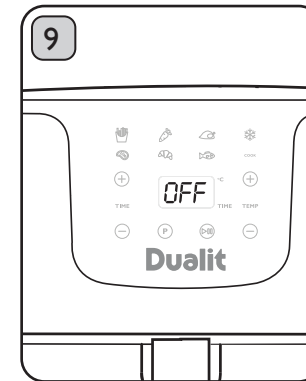

When the cooking cycle is finished the appliance flashes 'Off' on display, beeps 5 times and enters Standby Mode.

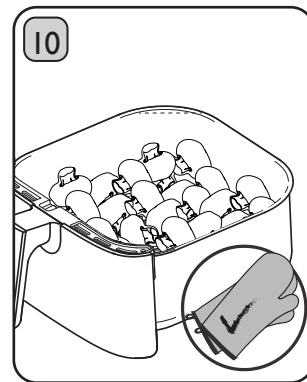

When removing, place Crisper Tray on heatproof surface. **Risk of injury.** If a supporting hand is needed to carry Crisper Tray in addition to the handle, use oven gloves. **Caution:** Crisper Tray base and sides will be hot. **Risk of injury.**

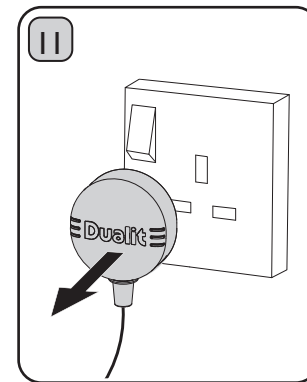

If you have finished using the appliance, unplug it from the mains. **Risk of fire.** Allow the appliance to cool for one hour before moving, cleaning or storing. **Risk of injury.**

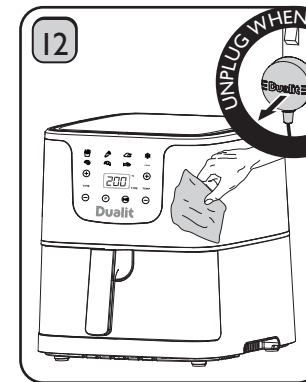

Always follow the 'Cleaning & maintenance' instructions on page 25 after every use. **Risk of fire and injury.**

TIPS FOR USING YOUR AIR FRYER



ENSURE YOU HAVE READ 'IMPORTANT SAFETY PRECAUTIONS' ON PAGE 04 AND FOLLOWED THE STEPS ON 'SETTING UP YOUR AIR FRYER' ON PAGE 11 AND 'PREHEATING YOUR AIR FRYER' ON PAGE 14. REFER TO THE 'MANUAL MODE COOKING AND RECOMMENDED COOKING GUIDELINES' ON PAGE 19.

ROASTING

- Select a joint/cut with even thickness. Ensure it fits into the Crisper Tray, leaving at least 2cm from the top of the meat to the top of the Crisper Tray and 4cm around the sides of the meat for air flow.
- Reduce the meat's packaging fan oven timings by approximately 20% and temperature by 10°C.

FRYING

- Evenly distribute food on the Crisper Plate. Ensure a 2cm gap between food and top of Crisper Tray. Do not squash food. See 'Maximum Weight of Food Per Cycle' on page 20. **Risk of fire.**
- To achieve even cooking results, we recommend turning/ shaking food several times during the cooking cycle. To do so, pull out the Crisper Tray, shake/ turn food and reinsert the Crisper Tray. Cooking will automatically resume. **Risk of injury.**

REHEATING

- Evenly distribute food on the Crisper Plate. Ensure a 2cm gap between food and top of Crisper Tray. Do not squash food. See 'Maximum Weight of Food Per Cycle' on page 21. **Risk of fire.**
- If reheating dry food such as chips, pizza or bread, we recommend sprinkling a small amount of water onto the food to prevent it from drying out.

BAKING

- Note, when baking in the Air Fryer, the outside of the food will cook faster than the inside.
- Never exceed a maximum load of 0.375kg cake mix per cooking cycle. **Risk of fire.** You will need to cook two layers (0.375g each) separately.
- Ensure cake moulds are non-flammable, smaller than 7 inches/ 18cm in diameter and a maximum height of 2.5 inches/ 7cm. Allow 3.5cm around the edge of the mould. Place the cake moulds on the Crisper Plate within the Crisper Tray. **Risk of fire.**

GRILLING

- Select food with even thickness. Ensure it fits into the Crisper Tray, leaving at least 2cm from the top of the meat to the top of the Crisper Tray and 4cm around the sides of food for air flow.
- If using metal skewers, take caution when removing, as the skewers will be hot. **Risk of injury.** Never use wooden skewers in the Air Fryer. **Risk of fire.**

DEHYDRATING

- Cut the food into 0.5cm slices, the thickness and size will depend on the food being dehydrated. Spread out the pieces evenly on the Crisper Plate.
- We recommend turning the food regularly (e.g. each time you have to reset the cooking cycle). This allows you to monitor the dehydration process and decide how much longer is needed.

CLEANING & MAINTENANCE



BEFORE CLEANING MAKE SURE THE APPLIANCE IS SWITCHED OFF, UNPLUGGED AND ALLOWED TO COOL FOR ONE HOUR BEFORE CLEANING. **RISK OF INJURY.** DO NOT SUBMERGE THE BODY, POWER CORD OR PLUG INTO WATER OR OTHER LIQUID, OR POSITION UNDER A WATER TAP.* **RISK OF FIRE, ELECTRIC SHOCK & INJURY.**

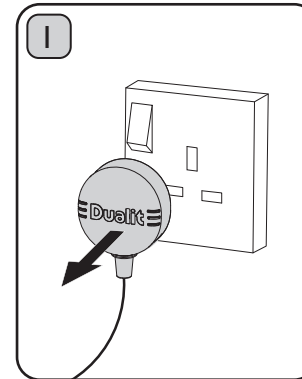

Always switch off, unplug and allow the appliance to cool for one hour before cleaning. Never use harsh abrasives or corrosive products. These could damage the surface. **Risk of product damage.**

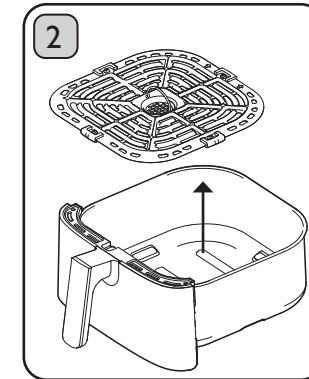

Remove Crisper Tray and Crisper Plate from the Air Fryer and wash using a mild liquid soap solution and soft, damp cloth or by placing the Crisper Tray and Crisper Plate in the dishwasher (top shelf recommended), using a wash cycle below 40°C.

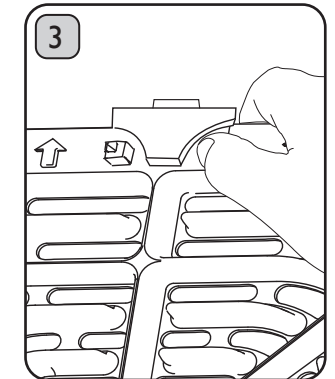

Remove the four Rubber Spacers from the Crisper Plate by pushing the raised indents of the Rubber Spacer through the holes on the Crisper Plate. Repeat on both sides of each of the Rubber Spacers. Clean using a mild liquid soap solution and soft, damp cloth.

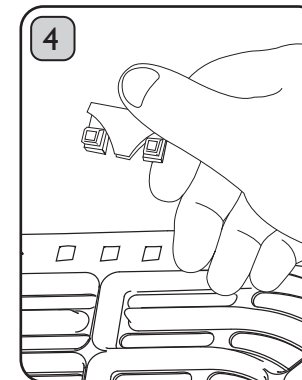

To reattach the Rubber Spacers, first soak them in water and then push each Rubber Spacer back onto the Crisper Plate, Ensure the tabs are fully pushed through or they could infiltrate food. **Risk of harm.**

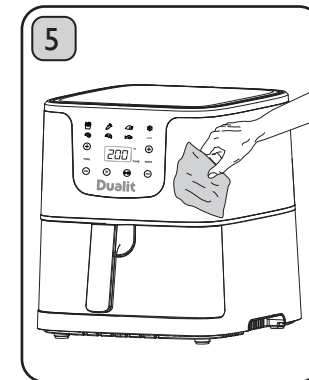

Wipe the exterior with a damp cloth. Dry immediately. Do not immerse the appliance in water. **Risk of electric shock.** Ensure no water enters the Air Inlet. **Risk of fire.** Do not try and remove the top cover of the Air Fryer. **Risk of injury.**

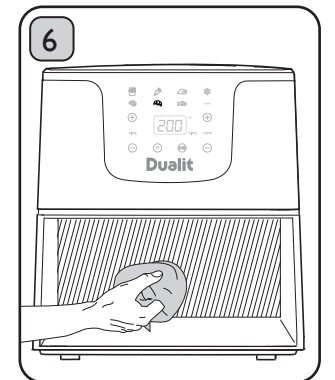

Wipe the interior top surface, sides, and base with a mild liquid soap solution on a damp, soft cloth or sponge. Ensure to avoid the element recess. **Risk of injury and product damage.**

CLEANING & MAINTENANCE CONT'D

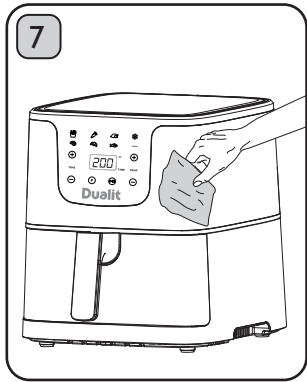

Dry immediately, with a soft, dry cloth.

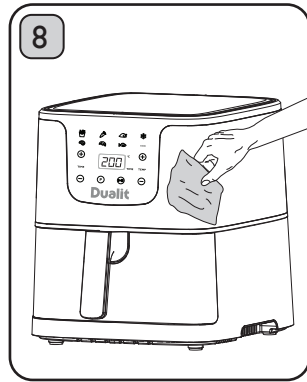

*It is important to clean the appliance and all parts after each use. This will prolong the life of your appliance. All other servicing or maintenance of the product must be performed by Dualit or a qualified electrical engineer.

TROUBLESHOOTING



Possible cause(s)	Solution(s)
THE AIR FRYER DOES NOT WORK.	
Internal fan does not come on.	Do not use the Air Fryer. Contact Dualit Customer Services. Risk of fire.
The appliance is not plugged in.	Put the main plug in an earthed wall socket.
You have not set the timer.	Adjust the settings to the required preparation time to switch on the appliance.
The plug fuse may have failed.	Replace the 13 amp plug fuse if necessary and check your residual current device (RCD). Never use the plug without the fuse cover fitted. Ensure replacement fuse is the same current value as the original. Replacement fuses are available and should be ASTA approved to BS.1362.
CRISPER PLATE DOES NOT FIT INTO THE CRISPER TRAY.	
Crisper Plate has the wrong orientation.	Insert Crisper Plate into Crisper Tray by aligning the arrows on one side of Crisper Plate to point away from Crisper Tray handle. Lower side without arrows into Crisper Tray first. Then lower side with arrows to point away from Crisper Tray handle.
Crisper Plate has been lowered into the Crisper Tray incorrectly.	Lower side without arrows into Crisper Tray first. Then lower side with arrows to point away from Crisper Tray handle.
You installed the Crisper Plate upside down, so the Ring Pull is on the underside.	Use the handle of a fork, positioned into one of the slots, or a blunt kitchen utensil, and prise the tray out.
CANNOT SLIDE THE CRISPER TRAY INTO THE APPLIANCE PROPERLY.	
There is too much food in the Crisper Tray.	Do not fill the Crisper Tray to capacity; ensure there is a gap of 2cm from the top of the food level to the top of the Crisper Tray.
WHITE SMOKE COMES OUT OF THE APPLIANCE.	
White smoke is emitted from the appliance.	Do not use the Air Fryer. Contact Dualit Customer Services. Risk of fire.
The appliance contains grease residues from previous use.	White smoke is caused by grease heating up in the Crisper Tray; ensure you are following cleaning instructions on page 25 and that the Crisper Plate and Crisper Tray are cleaned thoroughly after each use.

TROUBLESHOOTING CONT'D



Possible Cause(s)	Solution(s)
FRENCH FRIES ARE FRIED UNEVENLY IN THE AIR FRYER.	
The potatoes used were unsuitable.	Always use fresh potatoes that are evenly sliced. Make sure they stay firm and cook evenly by regularly turning/ shaking them during the cooking cycle.
The potato slices were not rinsed and dried adequately before air frying.	Rinse the potato slices thoroughly to remove the starch from the outside. Ensure you pat dry the potato slices with kitchen towel thoroughly before air frying. While oil is not necessary, if adding oil, ensure no more than 30ml is used and that the potatoes are evenly coated prior to cooking. Risk of fire.
FRENCH FRIES ARE NOT CRISPY WHEN THEY COME OUT OF THE AIR FRYER.	
The crispiness of the fries depends on the amount of oil and water in the potato slices.	Ensure you sure you pat dry the potato slices with kitchen towel thoroughly before adding the oil. Cut the potatoes into thinner slices for a crispier result. While oil is not necessary, if adding oil, ensure no more than 30ml is used and that the potatoes are evenly coated prior to cooking. Risk of fire.
THE INGREDIENTS USED IN THE AIR FRYER ARE NOT COOKED.	
The Air Fryer has been overloaded with food.	Put smaller batches of ingredients into the Crisper Tray. Smaller batches are fried more evenly.
The Crisper Tray and appliance have not been adequately preheated.	Always preheat the Crisper Tray and appliance for 3 minutes before inserting food.
The set temperature is too low.	Adjust the settings to the required temperature setting (see section 'Settings').
The cooking time is too short.	Adjust the settings to the required preparation time (see section 'Settings').

TROUBLESHOOTING CONT'D



Possible Cause(s)	Solution(s)
AIR FRIED SNACKS ARE NOT CRISPY WHEN THEY COME OUT OF THE AIR FRYER.	
The Air Fryer is not hot enough/ the food has not been cooked for long enough.	Increase the temperature and time of the cooking cycle.
You used a type of snack meant to be prepared in a deep fat fryer.	Use snacks made to be prepared in the oven, or lightly brush oil (never more than 30ml or oil/ lard) onto the snacks for a crispier result.
FOOD DOES NOT COOK EVENLY.	
You are not shaking food frequently enough during the cooking cycle.	Tips for shaking: if a recipe calls for 20 minutes cooking time and you want to shake the food half way through, set time to 10 minutes, then shake at end of cycle. Then put on again for another 10 minutes.
THE FAN COMES ON WHEN YOU TURN THE AIR FRYER OFF.	
You have recently run/ started a cooking cycle.	The fan stays on to cool the product after cooking. This is normal and to be expected.
THE AIR FRYER COMES ON AND STARTS COOKING WHEN PLUGGED IN.	
You did not turn the Air Fryer off before unplugging / turning off the Air Fryer.	Ensure you turn the Air Fryer off before unplugging.

GUARANTEE

This appliance is of excellent quality and construction. However, if any defects in materials or workmanship do appear during the relevant guarantee period, we will, at our discretion, either repair or replace the defective parts, free of charge, subject to the terms and conditions of our Guarantee shown below.

This Guarantee covers both parts and labour. Carriage is not included.

Your Guarantee period is as follows:

- 1 year

This Guarantee provides benefits which are additional to, and do not affect, your statutory rights. This Guarantee does not cover the cost of returning the product

to the dealer from whom it was purchased or to ourselves. This Guarantee applies only to products sold and located in mainland Great Britain. It does not cover liability in respect of or replacement of plugs, cables or fuses and also does not cover defects due to:

- Failure to use or maintain product in accordance with Dualit's instructions.
- The product being connected to an unsuitable electricity supply.
- Accidental damage to or abuse or misuse of the product.
- Product modification, except by Dualit or approved agent.
- Dismantling of or interference with the product.
- Theft or attempted theft of the product.

Before returning any product under this Guarantee, please check that:

- You have followed the product instructions correctly.
- Your mains electricity supply is functional.
- The defect is not due to a blown fuse.

If you wish to claim under this guarantee you should:

- Send the product, postage or carriage paid, to the dealer from whom it was purchased or to Dualit direct.
- Ensure that the product is clean and packed carefully (preferably in its original carton).
- Enclose details of your name, address and telephone number and when and where the product was purchased, together with proof of purchase (e.g. a till receipt).
- Give exact details of the nature of the defect.

This Guarantee does not cover any other claims whatsoever, including, without limitation, any liability for incidental, indirect or consequential damage, nor does it cover any claims for conversion or modification or for the costs of repair carried out by any third party without the prior consent of Dualit. If replacement parts are fitted to the product this will not extend the period of the Guarantee.

For further advice contact the Dualit customer helpline on +44 (0)1293 652 500 (09:00 to 17:00 Monday to Friday).

Alternatively, email Dualit at info@dualit.com or visit www.dualit.com

Do not throw away the appliance with the normal household waste at the end of its life, but hand it in to an official collection point for recycling. By doing this you help preserve the environment.

INSTRUCTIONS ON ENVIRONMENT PROTECTION



Do not dispose of this product in the usual household garbage at the end of its life cycle. Please hand it over to a collection point for the recycling of electrical and electronic appliances. The symbol on the product, the instruction of use or the packaging will inform you about the methods of disposal. The materials are recyclable as mentioned on its marking. By recycling, material recycling or other forms of re-utilization of old appliances you are making an important contribution to protect our environment. Please enquire about the community administration for the authorised disposal location.

REGISTER YOUR PRODUCT FOR THE CHANCE TO WIN A £250 PRIZE DRAW!

REGISTER YOUR PRODUCT

1. **Fast and efficient customer service** important safety advice, access to manuals and product information should you require assistance with your purchase.
2. **A library of mouth-watering recipes** and regular articles and blogs.
3. **Be the first to hear** about exciting new Dualit products.

Dualit recommends safety first: please register your product so that we can contact you in the unlikely event that a safety notification is issued. Remember to keep your receipt as proof of purchase.

DON'T FORGET TO REGISTER YOUR PRODUCT

WWW.DUALIT.COM/REGISTER

OR BY POST





Dualit®

CHECK OUT DUALIT'S

FOOD PREP RANGE



SCAN HERE
TO DISCOVER
MORE!

GB-A